

# EHP

## Hydraulic Dock Leveler

### Owners Manual



*Rugged. Dependable. PIONEER.*

P.O. Box 338 • Spring Hill, Tennessee 37174 • 1-800-251-3382 • fax: 931-486-0316 • [www.pioneerleveler.com](http://www.pioneerleveler.com)



# **WARNING**

**DO NOT install, operate or service product unless you have read and understand the Safety Procedures, Warnings, Installation and Operating instructions contained in this manual. Failure to do so could result in serious injury and/or death.**

# Safety Procedures



**WARNING:** Read and understand all safety practices and operating instructions Before installing, operating or servicing the dock leveler. Failure to follow the safety practices and operating instructions may result in property damage, serious bodily injury and/or death.

If you do not understand the safety procedures or the instructions, ask your supervisor to explain the safety procedures and/or teach you how to use the dock leveler.



**CAUTION:** The installer and/or operator MUST be very familiar with the operation, function and various parts of the PIONEER Pit Leveler PRIOR to installation and/or operation. If this is not the case, it is IMPERATIVE that the installer and/or operator read, and fully understand, the entire contents of this manual. **Be certain to read and understand all warning and caution statements contained in this manual prior to any installation, operation or servicing of this unit.**

- 1 Do not operate this equipment while under the influence of drugs or alcohol.
- 2 Do not stand in the driveway between the dock leveler and a truck backing in or pulling away.
- 3 Be sure the truck wheels are chocked, or the truck is held in place by a restraining device, before attempting to load or unload the truck.
- 4 Do not use the dock leveler if it looks broken or does not seem to work right. Lockout/tag out the defective equipment. Tell your supervisor immediately.
- 5 Do not operate the leveler with equipment, material or people on the platform and/or lip or in front of the leveler.
- 6 Be certain that equipment, material or people are not on the dock leveler before allowing a truck to pull out.
- 7 Keep clear of the dock leveler when it is moving. Never place your hands, arms, feet, or legs in the position where a moving dock leveler or a moving load could cause injury. **If in doubt, do not do it!**
- 8 If the dock leveler is not working properly, using the operation instructions in this manual, **do not use the dock leveler.** Contact your authorized PIONEER representative.
- 9 Never attempt to work under the dock leveler, for service or repair, without proper placement of maintenance strut.
- 10 Damage to the dock leveler, personal injury or death can result from abuse and/or negligent use of this equipment.
- 11 If you have any questions, or if a malfunction occurs which is not understood, ask your supervisor to contact your authorized PIONEER representative for assistance PRIOR to attempting any corrective measures.



**THIS IS THE SAFETY ALERT SYMBOL. IT IS USED TO ALERT YOU TO POTENTIAL PERSONAL INJURY HAZARDS. OBEY ALL SAFETY MESSAGES THAT FOLLOW THIS SYMBOL TO AVOID POSSIBLE INJURY AND/OR DEATH.**



## **WARNING**

**INDICATES A POTENTIALLY HAZARDOUS SITUATION WHICH, IF NOT AVOIDED, COULD RESULT IN SERIOUS INJURY AND/OR DEATH.**



**KEEP THIS MANUAL AND ALL SAFETY PROCEDURES IN A SECURE LOCATION WITH EASY ACCESS.**



**WARNING! READ AND UNDERSTAND THIS ENTIRE MANUAL PRIOR TO OPERATING.**



**WARNING! A DOCK LEVELER CAN BE A POTENTIAL THREAT TO PERSONS AND PROPERTY, IF NOT USED PROPERLY. SAFE OPERATION IS THE RESPONSIBILITY OF THE OPERATOR.**



**WARNING! DO NOT ENTER THE AREA IN FRONT OF OR BELOW THE DOCK LEVELER. SERIOUS PERSONAL INJURY AND/OR DEATH MAY RESULT.**



**WARNING! DO NOT ATTEMPT TO INSTALL, MAKE REPAIRS OR ADJUSTMENTS. ONLY A TRAINED AND AUTHORIZED SERVICE TECHNICIAN SHOULD PERFORM REPAIRS OR ADJUSTMENTS. ONLY A QUALIFIED CONTRACTOR/SUB-CONTRACTOR SHOULD PERFORM THE INSTALLATION PROCESS. CONTACT YOUR LOCAL PIONEER DEALER FOR ASSISTANCE.**

 **WARNING**

- \*\*Before doing any electrical work, make certain the power is disconnected and the leveler is properly tagged or locked out.**
- \*\*All electrical work must be done by a qualified technician and must meet all applicable codes.**
- \*\*If it is necessary to make troubleshooting checks inside the control panel with the power on, USE EXTREME CAUTION.**
- \*\*Do Not place fingers or uninsulated tools inside the control box. Touching wires or other parts inside the control box could cause electrical shock, serious injury and/or death.**

**SECTION 1****EHP Series****INSTALLATION INSTRUCTIONS  
RECEIVING AND HANDLING**

RECEIVING:

**WARNING**

Before installing the dock leveler, read and follow the safety procedures and the operating instructions. Failure to follow the safety procedures could result in serious injury and/or death.

Check for possible damage or missing parts immediately upon receipt of unit. **Note any damage or possible damage on receiving papers.**

Prepare any claims against carrier if necessary.

Notify PIONEER of any damage or missing parts.

HANDLING:

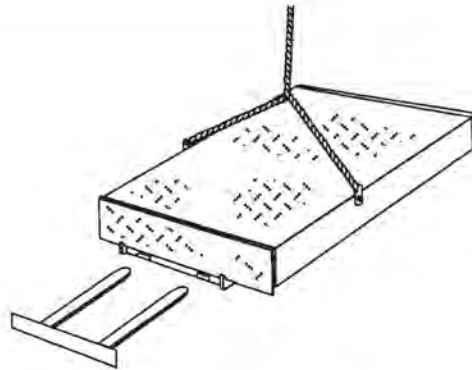

(Figure A)

Move leveler into position by using:

- chain sling inserted into side plate holes. (See Figure A) or
- fork lift, inserted in front base angle (See Figure A)

**NOTE:**

**Control box, two bumpers, and weather seals, if applicable, are strapped under leveler. Handle with care to avoid damage to these components.**

**SECTION 1****EHP Series****INSTALLATION INSTRUCTIONS  
INSTALLATION**

INSTALLATION: (Consists of 3 phases)

Pit preparation

Leveler Preparation

Leveler Installation



**Caution:** Before you start to install the leveler, use proper safety signs and barriers to separate the work area from the remainder of the dock.

**WARNING**

Never allow anyone to stand on or near dock leveler when it is being lifted or placed into the pit. Failure to follow this warning can allow the dock leveler to fall, tip, or swing into people, resulting in serious injury and/or death.

**PIT PREPARATION AND ELECTRICAL INSTALLATION:**

**Figure B**

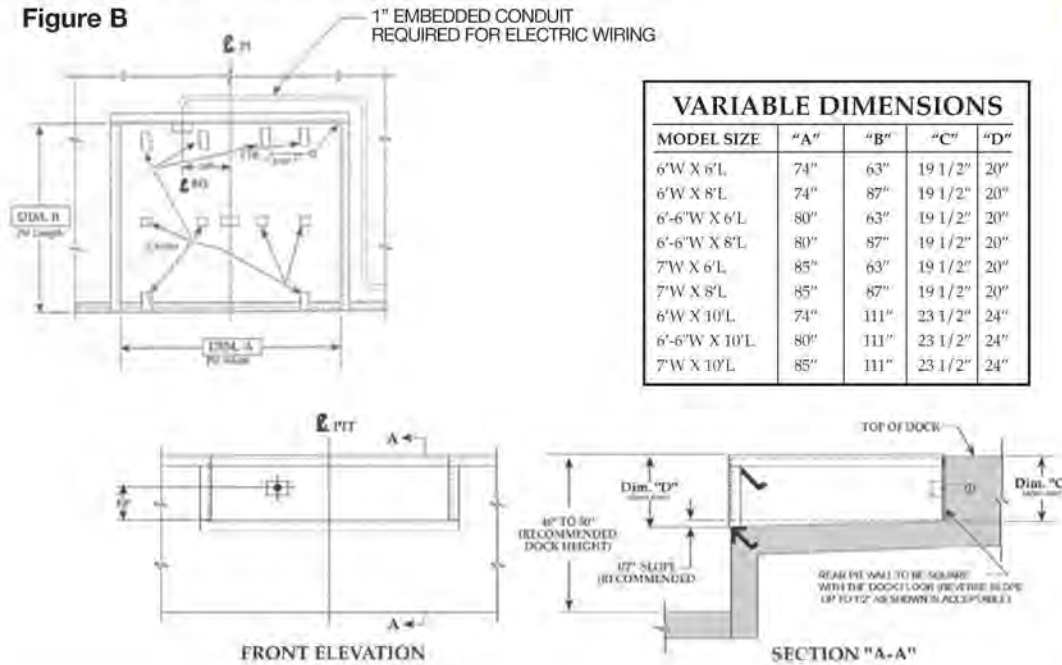

Before welding the rear frame, cover the rear weather seal with a piece of sheet metal to prevent setting fire to the weather seals. Failure to do so may result in property damage.

1. Examine pit. Pit walls should be square and plumb. Clean all debris from pit. The floor at the rear and both sides should be level.
2. Measure pit dimensions. (See Figure B for accurate dimensions.)

Verify that pit walls are:

- Square
- Plumb

Place shims in general locations on pit floor before lowering leveler into place in pit.

[Pit depth at shim locations (minus 19" or minus 23" on 10 ft. units) equals shims thickness.]

NOTE: Shims are to be placed directly under rear frame uprights, under base of cylinder, under base frame support struts, and under lip keepers, See Figure B, page 3 & Figure D, page 5.

**Figure C**

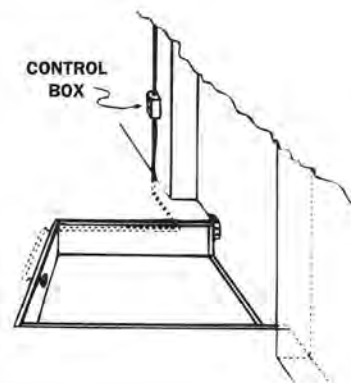

3. Install control box on wall near pit. (See Figure C)
4. Install wire leads for motor per wiring diagram. (See pages 15 - 18)

Wire must be installed through conduit. (Conduit to be supplied by customer.) Additional wire leads may be used to supply temporary power to leveler from control box. Wires for motor must be long enough to reach mid section of leveler while in front of opening. this extra may be cut back and discarded after installation.

**Standard Applications:**

1. Install the control panel on a wall adjacent to the overhead door at approximately 48 in. - 50 in. (1219 mm - 1270 mm) above the floor level. Make sure to mount where control panel is clear of obstructions.
2. Drill a hole for the power supply conduit (supplied by others) in the bottom of the control panel. All holes drilled through the control panel must be through the bottom of the enclosure.
3. Fused disconnect must be installed per latest edition of UL508A and NEC requirement, located within a 50' radius and be visible from the control panel location.

**SECTION 1**      **EHP Series**      **INSTALLATION INSTRUCTIONS RECEIVING AND HANDLING**

**LEVELER PREPARATION**

 **WARNING**

Fully support the lip, while working under the leveler. The lip plate could fall causing serious injury and/or death.

 **WARNING**

Inadequate lifting equipment or practices can cause a load to fall unexpectedly. Make sure the lifting equipment is in good condition. Never allow anyone to stand on or near the dock leveler when it is lifted or placed into the pit. Stand clear of the dock leveler when it is placed into the pit. Failure to follow this warning can cause serious injury and/or death, if the dock leveler tips, swings or falls.



**CAUTION**

Route temporary power cord clear of edges and resting surfaces so that it is not damaged during lifting and placement.

1. Position leveler directly in front of pit.
2. Cut restraining band on lip.
3. Connect temporary wire leads to proper wire grouping at motor.

**NOTE:** Unit may fail to operate correctly at this point if temporary power does not supply adequate voltage. **DO NOT** make adjustments to leveler. Provide proper voltage before attempting to operate leveler. (See Electrical Page 13 & 14)



## LEVELER PREPARATION

4. Check motor operation.
- 
5. Check fluid level in hydraulic reservoir. Check all hydraulic hose connections and fittings.

If unit does not raise when motor activates, rotation may be wrong. Recheck connections per wiring diagram to correct rotation.  
**NOTE: Do not attempt to adjust valves until contacting an authorized Pioneer Dealer or the factory.**

With leveler in raised position and maintenance strut engaged reservoir should be half full. If necessary, fill to correct level, using aircraft hydraulic fluid

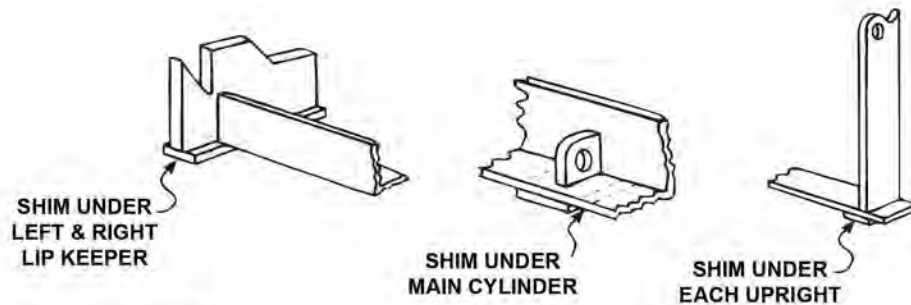

FIGURE D

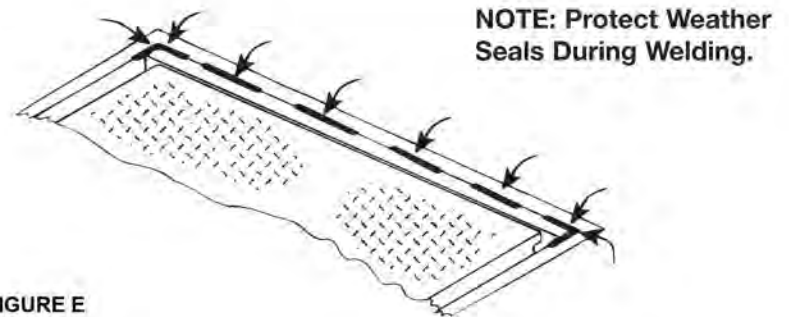

FIGURE E

**20" Lip Keeper Installation Instructions**

Two separate lip keeper angles are provided with every unit that has a 20" lip. These angles are tack welded to the leveler base frame just behind the lip.

Break each one loose and set the leveler into the pit per the installation instructions in the owner's manual.

Prior to angle installation or shimming make sure that the unit is snug against the embedded curb angle at the back of the pit.

Place the lip keepers under the front base angle on either side of the unit with the top of the angle protruding out past the base 1/4" in the front and on the left for the left hand keeper and on the right for the right hand keeper. This will facilitate welding.

Fully weld the keeper angle to the base angle.

Proceed with shimming per the owner's manual.

TOP VIEW

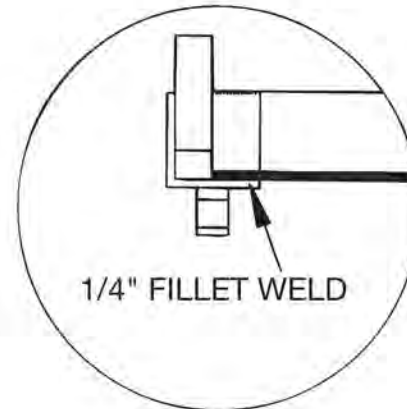

PICTORIAL VIEW

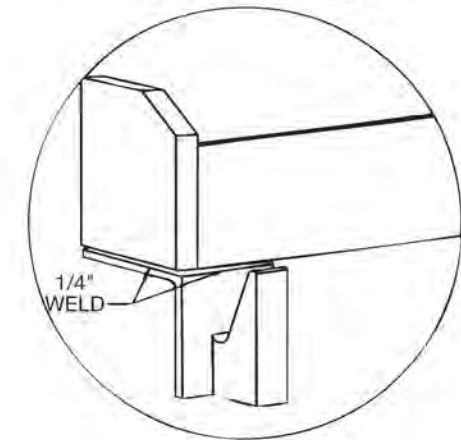

FRONT VIEW

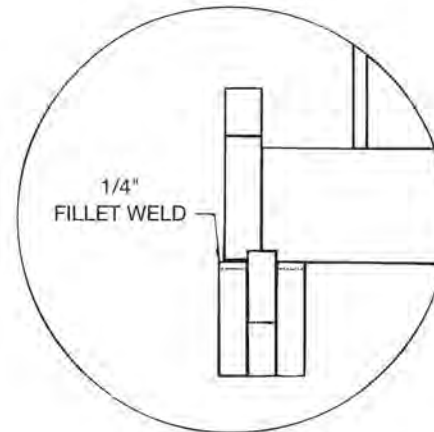

SIDE VIEW

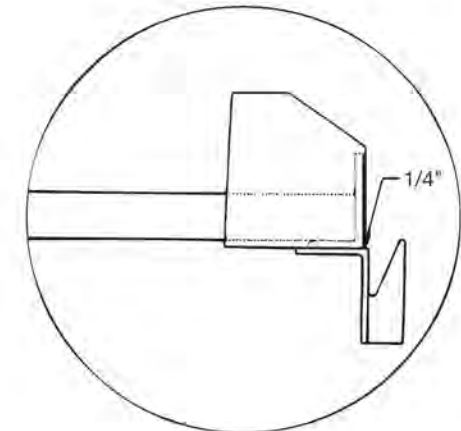

## LEVELER INSTALLATION:

 **WARNING**

DO NOT work under the dock leveler, ramp, or lip unless the maintenance strut is in place.

 **WARNING**

Keep fingers, hands, and head away from the lip when it is released. Fingers, hands, or head could be struck by or caught between the lip and other parts of the dock leveler causing serious injury and/or death.

 **WARNING**

Improper installation of this equipment or installation into aged or unsound concrete could result in serious injury and/or death.

**CAUTION**

Welding with the dock leveler's power connected can damage electrical components. If the dock leveler has previously been electrically connected, turn off power to control box and unplug all dock leveler electrical cords from receptacles in the rear pit wall before welding. Ground welder to dock leveler. Failure to do so can result in product damage.

Be certain that the rear hinge assembly is held tightly against the rear pit curb angle before welding.

**CAUTION**

If front and rear pit curb angles are not parallel DO NOT attempt to shim dock leveler supports to match pit angles. The front supports and rear frame angle must be parallel for proper operation of the dock leveler. Add or subtract shims as required.

1. Place leveler into pit opening.

Allow one inch (1") equal clearance between leveler sides and pit walls. Rear frame angle of leveler should be tight against and flush with rear curb angle for proper welding.

2. Recheck shim packs to ensure leveler is at proper height, flush with floor level, front and rear.

Shims must be placed properly under each rear frame upright, under the main cylinder, under the rear frame support struts (HP Only) and front lip keepers. (See Figure D, page 5 for close up view and Figure B, page 3 for approximate shim locations.)

Skip weld rear of leveler to curb angle (weld center first, then ends) and front shims to leveler and curb angle. (see Figure E, Page 5.) Protect rear weather seals from weld spatter if applicable.

**LEVELER INSTALLATION:**

3. Bring deck section of leveler to fully raised position.

Use temporary power, or lift slowly with fork lift under lip edge

4. Place maintenance strut securely under deck.

EHP - Maintenance strut is taped to the base frame for shipping. Remove the tape, place the bottom of strut into the cup on the base frame and the top into the cup welded to the bottom side of the lip.

5. Weld all shims securely in place.

6. Connect permanent power source to control box on wall.

7. Make permanent electrical hook up to motor.

Leveler should now be ready to operate

 **WARNING**

Hydraulic pressure must be maintained on the ramp to hold it in the raised position until the maintenance strut is in place. **DO NOT WORK UNDER THE DOCK LEVELER RAMP OR LIP UNLESS MAINTENANCE STRUT IS SECURED.**

 **WARNING**

Keep hands, fingers and head away from the lip when the raise button is released. The lip and dock leveler are free to move downward when hydraulic pressure is removed from cylinders.

## ABOVE DOCK USE:

8. Close control box and activate leveler until lip fully extends.

9. Store maintenance strut.

Two person operation. One person holds pressure on OPERATE button while a second person stores the maintenance strut. Do not hold pressure on OPERATE button for more than 10 seconds.

EHP Series

10. Allow leveler to descend to below dock position.

Release OPERATE button. Leveler will drift down to below dock.

EHP Series

10. A Raise leveler to stored position

Push OPERATE button and raise leveler above dock until lip closes. Release OPERATE button and leveler will store in home position with lip in keepers.

11. Recheck all hydraulic hose connections and fittings.

Make sure all fittings are snug and no leaks are present.

12. Install bumpers on dock face.

Securely bolt bumpers to dock face as close to pit opening as possible. Bumpers should be flush with dock floor or 48" off ground. Raised bumpers should be supported to floor from behind.

13. Complete weld at rear of leveler.

Weld shall cover approximately 50% of the length of the rear angle. Ensure welds are placed directly behind frame uprights: (4 each on 6' wide models, 6 each on 7' wide models) and at ends of angle. (See Figure E, page 5) (Protect weather seals during welding).



**CAUTION: Contact your PIONEER representative or the factory if a malfunction occurs which is not understood. DO NOT attempt to correct situation without proper information and understanding, as this may damage components and void the warranty.**

**! WARNING**

ALWAYS secure the vehicle with a vehicle restraint and wheel chocks before operating the dock leveler.

- \* DO NOT operate leveler with anyone standing on or in front of leveler.
- \* DO NOT lift the leveler by hand.
- \* ALWAYS keep fingers, hands, feet, and head clear of all moving parts.

**! WARNING**

If the lip does not fall to the stored position, the dock leveler requires maintenance or adjustment. Notify you supervisor. DO NOT use dock leveler until it has been repaired. Failure to do so could result in serious injury and/or death.

**! WARNING**

ALWAYS be certain that the truck wheels are chocked, and that the truck is locked in place by a truck restraining device and the brakes set before loading or unloading. Visually inspect vehicle restraint to make sure it is properly engaged. Trucks pulling away unexpectedly can cause uncontrolled drop of the dock leveler, which can result in serious injury and/or death.

**! WARNING**

If the lip does not fully extend, do not lift by hand. Restore leveler to dock level and try again. If lip still does not fully extend, the dock leveler requires maintenance or adjustment. Notify your supervisor. DO NOT use the leveler until it has been repaired. Failure to do so could result in serious injury and/or death.

**! WARNING**

Visually check that the lip is supported by the truck bed or the ramp is supported by both front lip keepers before driving or walking on the ramp.

ALWAYS return the dock leveler to its dock level (stored) position before allowing the truck to leave the dock. If the truck pulls away before the dock leveler is stored, the lip will fall to its pendant position and may not be supported by the lip keepers. In addition, failure to properly store the dock leveler may leave the leveler in a position below the level of the dock floor. These conditions may result in unexpected drop of personnel or material handling equipment and result in serious injury and/or death.

**! WARNING**

*Before servicing the dock leveler, read and follow the Safety Practice and the operation section of this manual. Be certain, before climbing under the dock leveler, that the MAINTENANCE STRUT is SECURELY IN PLACE.*

**LIP EXTENDED FOR ABOVE DOCK USE**

1. Press and hold the OPERATE button on the control box.

Release the button when the platform raises and the lip fully extends.

2. The platform will descend with lip extended until lip rests on truck bed.

The leveler allows for up and down movement of truck during loading or unloading.

3. (EHP Series)  
When truck departs, the leveler will descend to below dock with the lip extended. Lip will slowly close.

(EHP Series)  
4. Push OPERATE button to recycle leveler.

Push OPERATE button and raise leveler above dock. Lip will retract automatically. Release OPERATE button as soon as lip fully retracts and leveler will store in home position.

**SECTION 2****EHP Series****OPERATING INSTRUCTIONS****RECYCLE PROCEDURE WITH TRUCK AT DOCK:**

1. Press and hold the OPERATE button. (or turn & hold the switch)
2. Release the Operate button.

Hold the button until the platform reaches maximum height and lip fully retracts.

Leveler will descend to stored, cross traffic position.

**SECTION 2****EHP Series****OPERATING INSTRUCTIONS  
BELOW DOCK OPERATION****LIP EXTENDED FOR UNLOADING BELOW DOCK:**

1. Press and hold the OPERATE button.
2. Release the Operate button.

Wait until the platform raises and the lip begins to extend.

Leveler will settle between dock floor and truck.

**SECTION 2****EHP Series****OPERATING INSTRUCTIONS  
AUTOMATIC SAFETY STOP****AUTOMATIC SAFETY STOP**

If lip of leveler should become unsupported while a load of 1,000 pounds or greater is on the platform, the hydraulic system automatically locks the platform in position, supporting the load.

To restore the leveler to normal operation:

1. Remove the load.
2. Press the Operate button until lip fully retracts. Immediately upon full retraction release operate button prior to lip re-extension.



**ALWAYS SECURE LEVELER WITH LIP IN KEEPERS TO INSURE SAFE CROSS TRAFFIC USE.**

**\*\*NOTE: FORKLIFT TRAVEL NOT TO EXCEED 5mph\*\***



**SECTION 3****EHP Series****MAJOR COMPONENTS**

HYDRAULIC FLUID CONTENT	Levelers are shipped filled with aircraft hydraulic fluid.
ELECTRICAL Motor:	1 HP, 15 minute duty cycle
Control Box: (EHP Series)	Wall mounted rotary box (15volt/single phase only) standard. Meets N.E.M.A. 4X. Circuit protection provided by others.
Optional Control Box (EHP Series) (required for 3 phase or 230 volt 1 phase):	Wall mounted polymer box, with exterior reset button. Meets N.E.M.A. 4X.

MOTOR VOLTAGE (AC)	PHASE	AMP DRAW (RUNNING)	POWER (amperage) REQUIREMENT
115	1	16.0	30
230	1	8.0	20
208-220-240	3	4.7	15
440-460-480	3	2.1	15

1 HP, 1 ph motor draws 25 amps to start motor.

To avoid voltage drop, Pioneer recommends #10 wire on short runs and #8 wire on long runs. See page 14.

**Consult code requirements.**



**CAUTION: A MOTOR CAN BURN OUT FOR ANY OF THE FOLLOWING REASONS:**

1. Hook up to incorrect line voltage.
2. Single phasing of polyphase motor caused by a blown fuse or loss of one leg of electrical supply.
3. Low voltage to motor due to insufficient line capacity. This is the most common with 110V, 1 phs operation.

# Choose the Right Gauge Wire

The correct wire gauge (size) for your project is based on the amperage, or power, required and the distance the wire travels. The chart below helps you determine what gauge wire you need. Remember, the smaller the number, the larger the wire. For example, a 6-gauge wire is larger than an 8-gauge wire.

GAUGE GUIDE FOR MAXIMUM ALLOWABLE WIRE LENGTH, 2% NOMINAL VOLTAGE DROP									
AMPS	WATTS	COPPER CONDUCTORS							
		UP TO 50'	UP TO 100'	UP TO 150'	UP TO 200'	UP TO 250'	UP TO 300'	UP TO 400'	UP TO 500'
15	1800	14 Gauge	12 Gauge	10 Gauge	6 Gauge	6 Gauge	6 Gauge	4 Gauge	4 Gauge
20	2400	12 Gauge	10 Gauge	8 Gauge	6 Gauge	6 Gauge	4 Gauge	4 Gauge	2 Gauge
30	3000	10 Gauge	8 Gauge	6 Gauge	6 Gauge	4 Gauge	4 Gauge	2 Gauge	2 Gauge
40	4800	8 Gauge	6 Gauge	4 Gauge	4 Gauge	2 Gauge	2 Gauge	1 Gauge	1/0 Gauge
50	6000	6 Gauge	6 Gauge	4 Gauge	4 Gauge	2 Gauge	1 Gauge	1/0 Gauge	2/0 Gauge

This information is provided as a general guideline only. For safe wiring practices consult the National Electric Code, local building codes and regulations, and your local building inspector. Always remember that installation of electrical wire can be hazardous and, if done improperly, can result in personal injury or property damage.

Canadian codes differ from the above charts. Check your provincial codes before completing your project

Chart and illustration provided and copyrighted by General Cable Technologies Corporation, makers of Romex(R) brand cable.

This equipment is shipped from the factory fully tested and operative.

The majority of operating problems are caused by **IMPROPER VOLTAGE** or **UNNECESSARY ADJUSTMENT BY UNQUALIFIED PERSONNEL!**

To comply with warranty, contact your local Pioneer representative or call the factory direct if you are experiencing difficulty with the leveler during the warranty period. **DO NOT RISK VOIDING THE WARRANTY BY TAMPERING WITH THE EQUIPMENT.**

**THIS STATEMENT IS VALID FOR BOTH EHP AND HP UNITS.**

**CAUTION:**

**Always place maintenance strut and disconnect power before climbing under or placing hands under leveler**

**EHP Series 1 Phase Control Box**

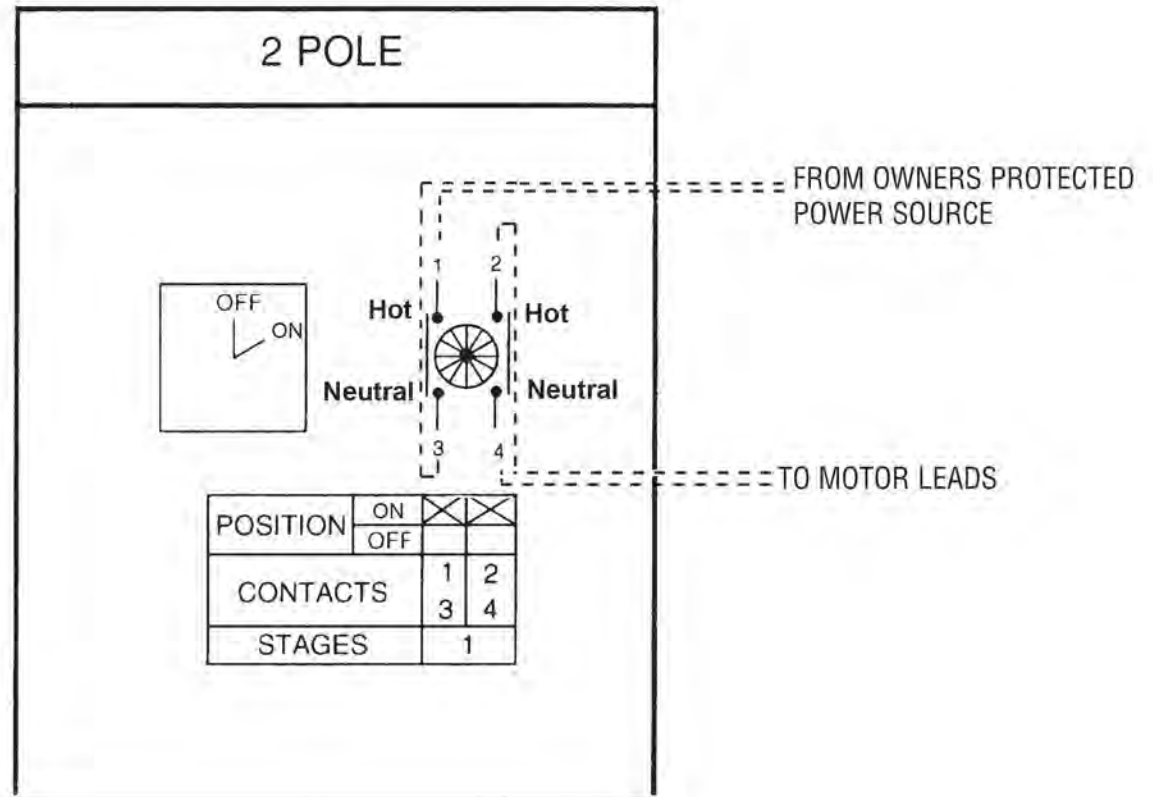

# EHP Series – 240 / 480 Volt Three Phase

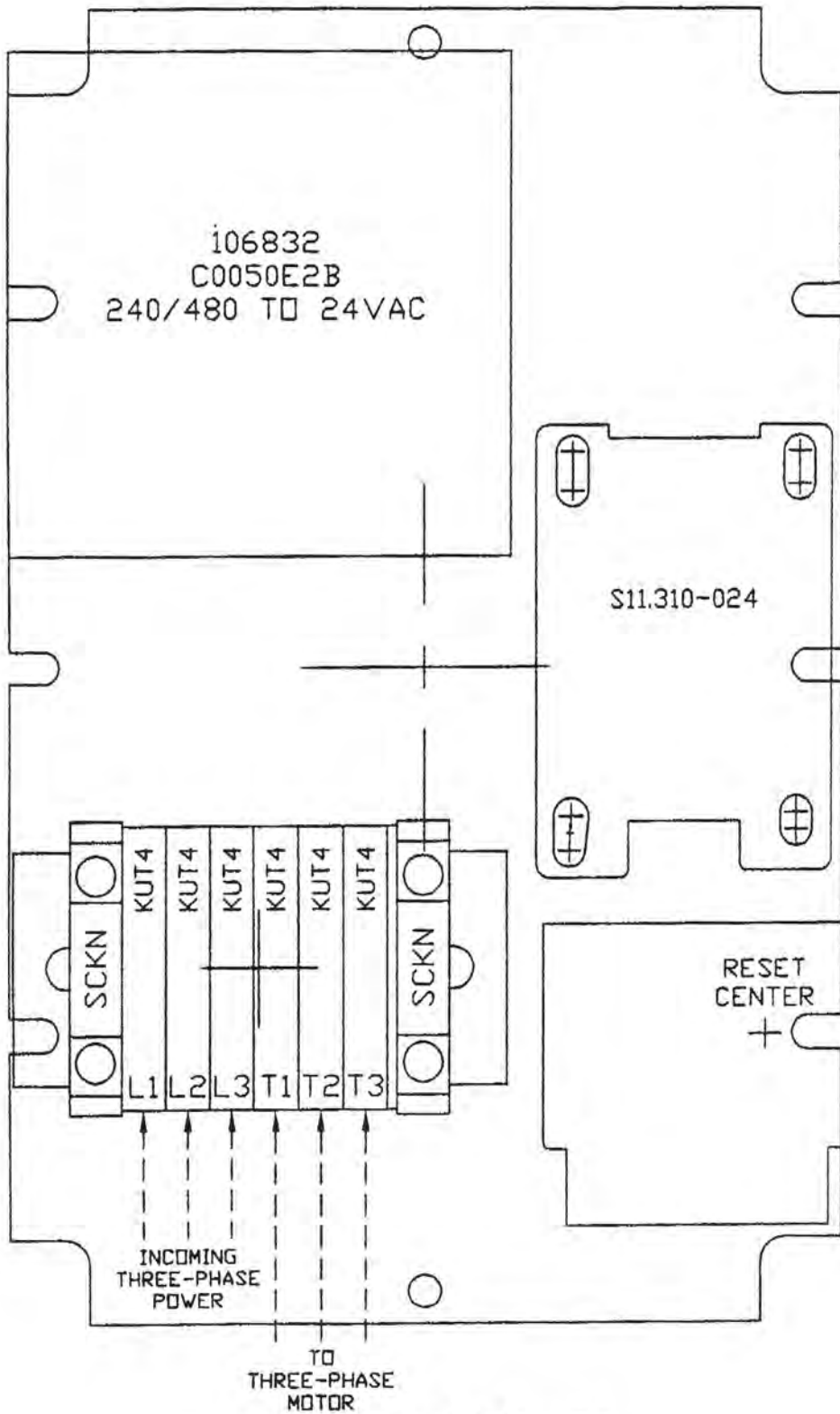

118975-000-61

08-27-03

**WARNING**

Read and follow the safety procedures in this manual before doing any service or repair to the dock leveler. ALWAYS SECURE LEVELER WITH MAINTENANCE STRUT BEFORE CLIMBING INTO THE DOCK LEVELER PIT OR DOING ANY MAINTENANCE OR REPAIR UNDER THE DOCK LEVELER. Failure to do so could result in serious injury and/or death.

SYMPTOM:	PROBABLE CAUSE:	CORRECTION:
<p>RAMP WILL NOT RAISE FROM STORED POSITION:</p> <p>Motor not running in Normal mode when Operate button is pressed.</p>	<p>1. Incorrect or disconnected electrical hook-up.</p>	<p>1. Review wiring diagram and check connections.</p>
	<p>2. Blown fuses or open circuit breaker.</p>	<p>2. Replace bad fuses.</p> <p>Reset circuit breakers.</p> <p>Determine and correct other electrical problems.</p>
	<p>3. Loss of line voltage.</p>	<p>3. Check lines and repair or replace if necessary.</p>
	<p>4. Open overload relays on motor starter in control panel. (EHP Series on optional control box only)</p>	<p>4. Allow to cool.</p> <p>Push "RESET" button located in control box.</p>
	<p>5. Burned motor.</p>	<p>5. Determine cause of burn-out.</p> <p>Correct problem.</p> <p>Replace motor. (Contact factory.)</p>

<b>SYMPTOM:</b>	<b>PROBABLE CAUSE:</b>	<b>CORRECTION:</b>
<p>RAMP WILL NOT RAISE OR LIP WILL NOT EXTEND FULLY:</p> <p>Motor running or humming in normal mode</p> <p>(1 ph motor)</p>	<p>1. Voltage drop, probably due to insufficient line capacity, resulting in blown fuses, tripped circuit breakers or motor hum.</p>	<p>1. Test voltage at motor starter with motor running. Test for amperage drain. (Low voltage/high amperage indicates inadequate feed line for distance of run.) Replace feed line with adequate wire size.</p>
<p>(1 ph motor)</p> <p>(3 ph motor)</p>	<p>2. Wrong rotation.</p> <p>2. Wrong rotation.</p>	<p>2. See wiring instructions on motor</p> <p>2. Reverse T1 and T3 at terminal strip. (See Figure H, Page 18)</p>
<p>(3 ph motor)</p>	<p>3. Motor single-phasing.</p>	<p>3. Check for bad fuse or loss of power in one line due to loose connections or tripped breakers or overloads.</p>
<p>(1 ph or 3 ph motor)</p>	<p>4. Load on ramp.</p>	<p>4. Remove the load. Ramp is not designed to lift more than its own weight.</p>
<p>(1 ph or 3 ph motor)</p>	<p>5. Low fluid.</p>	<p>5. Refill if needed. Check fittings and hoses and tighten if loose.</p>
<p>(1 ph or 3 ph motor)</p>	<p>6. Motor or pump physically damaged.</p>	<p>6. Replace.</p>

SYMPTOM:	PROBABLE CAUSE:	CORRECTION:
RAMP WILL NOT LOWER AFTER BEING FULLY RAISED:	<ol style="list-style-type: none"> <li>1. Physical obstruction.</li> <li>2. Safety stop in hydraulic fittings has locked up.</li> </ol>	<ol style="list-style-type: none"> <li>1. Check and remove. (Always use maintenance strut for safety.)</li> <li>2. Push and release the Operate button to unlock and allow the unit to descend. If symptom persists, consult factory.</li> </ol>
RAMP EXPERIENCES LONG DELAY BEFORE RAISING:	<ol style="list-style-type: none"> <li>1. Air in hydraulic system.</li> </ol>	<ol style="list-style-type: none"> <li>1. Consult factory.</li> </ol>
RAMP WILL NOT AUTOMATICALLY RETURN FROM BELOW DOCK:	<ol style="list-style-type: none"> <li>1. Unit is not designed to automatically return to stored position.</li> </ol>	<ol style="list-style-type: none"> <li>1. Press Operate button and raise leveler until lip fully retracts. Release Operate button and leveler will store in home position.</li> </ol>

**CAUTION:**

Contact your PIONEER representative or the factory if a malfunction occurs which is not understood. **DO NOT** attempt to correct the situation without proper information and understanding as this may damage components and void the warranty.

 **WARNING**

**BEFORE SERVICING THE DOCK LEVELER, READ AND FOLLOW ALL SAFETY PROCEDURES IN THIS MANUAL. FAILURE TO DO SO COULD RESULT IN SERIOUS INJURY AND/OR DEATH.**

 **WARNING**

**BEFORE SERVICING THE DOCK LEVELER, ALWAYS POSITION TRAFFIC CONES OR A BARRICADE BEHIND THE DOCK LEVELER. ALSO POSITION CONES OR BARRICADES IN FRONT OF THE LEVELER TO WARN AGAINST VEHICLE TRAFFIC.**

- \* ALWAYS NOTIFY A FOREMAN OR SUPERVISOR THAT YOU ARE WORKING UNDER THE EQUIPMENT.
- \* ALWAYS MAKE SURE THAT THE MAINTENANCE STRUT IS IN POSITION BEFORE WORKING UNDER THE LEVELER.
- \* ALWAYS MAKE SURE THAT THE OVERHEAD DOOR IS SECURELY HELD IN THE RAISED POSITION.

**SERVICE AND MAINTENANCE**

Pioneer recommends periodic inspection and servicing of the “EHP” Hydraulic dock leveler to assure proper operation and maximum life span of the dock leveler. Units should be inspected a minimum of every six months and, if needed, (See ”OPERATING INSTRUCTIONS, page 10) adjusted and lubricated. Adjustment of Hydraulic valves are considered normal maintenance and are not covered under warranty. Contact your local Pioneer dealer to secure a complete maintenance plan.



ITEM	DESCRIPTION
4	Deck Cylinder with Velocity Fuse
5	Pins & Clevis Keys, Deck Cylinder
14	Motor & Pump Assembly 1 HP/1PH Motor & Pump Assembly 1 HP/3 PH (OPT.)
8	Hydraulic Hose (Pump to Deck Cylinder)
9	Hose Assembly, Pump to Lip Cylinder
10	Hose Assembly, Deck Cylinder to Lip Cylinder
6	Lip Cylinder
7	Pins & Clevis Keys, Lip Cylinder

**EHP Series Hydraulic System**

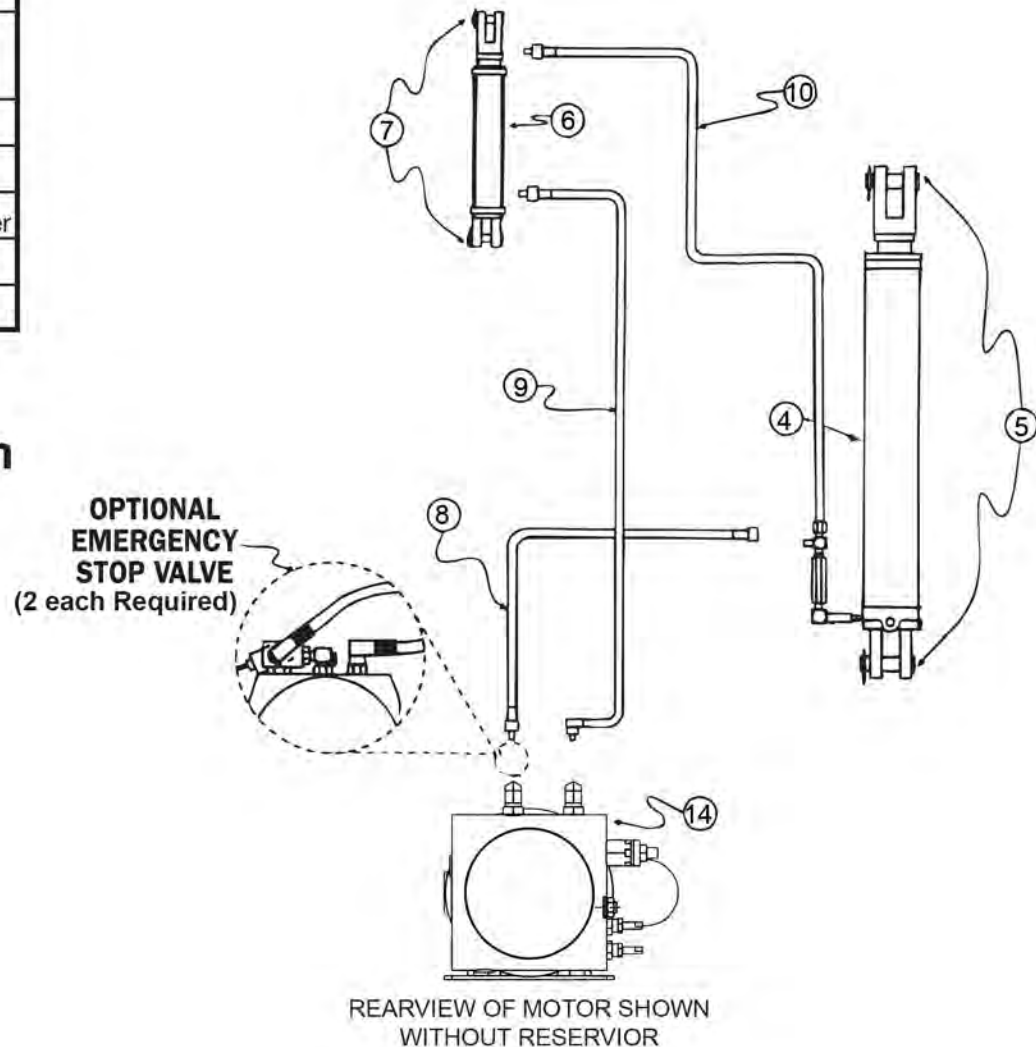

**PIONEER DOCK EQUIPMENT DOCK LEVELER "EHP" SERIES**

ITEM NO.	DESCRIPTION
1	LIP PLATE ASSY, 16"
2	LIP HINGE PIN
11	FULL RANGE TOE GUARDS
3	DECK REAR HINGE KIT
12	115 VOLT SINGLE PHASE CONTROL BOX
13	208 VOLT 1 PHASE & ALL 3 PHASE CONTROL BOX

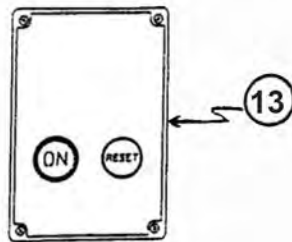
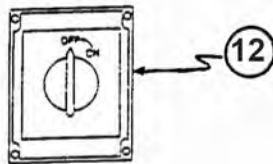
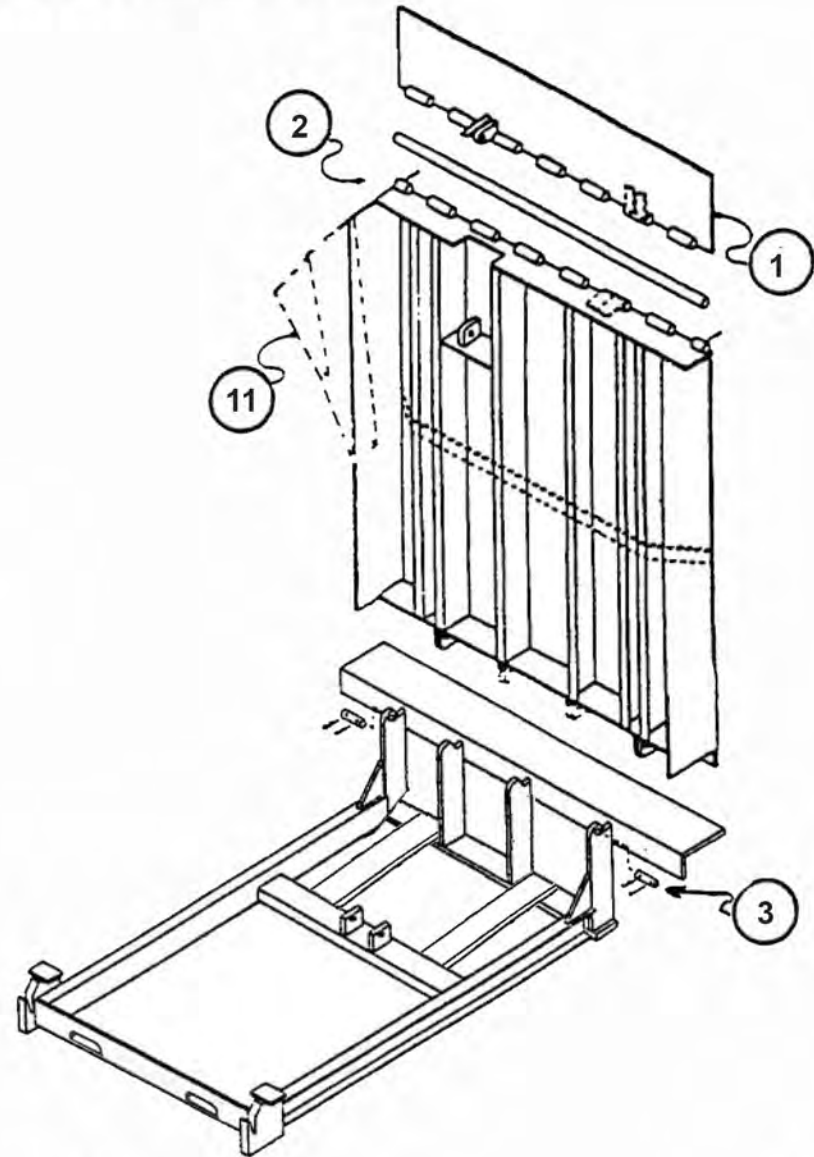



## **Warranty Procedure**

**The information on the Warranty Claim Request Form must be provided with all warranty claims.**

When a call is received with a warranty problem a Customer Service number (CSF ####) will be issued for that problem only and cannot be used again without prior approval. This number must be on all invoices submitted for payment and on all correspondence.

Before and after pictures of all the work performed must be supplied with each claim. If you take digital pictures, e-mail them to [connerh@pioneerleveler.com](mailto:connerh@pioneerleveler.com). If you use a film camera forward the film to Pioneer Loading Dock Equipment, PO Box 338 Spring Hill, TN 37174, Attn: Warranty Dept.

No claim will be considered for processing without the required information.

Pioneer's Warranty Policy for payment is a credit that will be applied to your account for payment. A copy of the credit memo will be sent to your billing address. If a check payment is required, the request must be in writing. The request then has to be approved by Pioneer's accounts payable department.

### **Replacement Part under Warranty**

Any replacement parts will be invoiced at the time of shipment. Credit will be given when the damaged parts are returned to Pioneer. Any exceptions will be determined by Pioneer. At Pioneer's discretion, replacement parts will be shipped either UPS ground or OTR truck. Any other requested method of shipment will be charged to the dealer. (i.e. UPS next day-Fed-Ex., etc.)

All returned parts will be issued a Return Authorization Number (RGA ####). A form will be faxed with the RGA number. A signed copy is to be faxed to 1-931-486-0316 and returned with the parts. The Return Authorization is good for 30 days. The RGA# must be listed on all returns, using the RGA Form as a packing list.

No credits will be issued without prior proper authorization.

A copy of the credit memo will be sent to your billing address. The credit will be given against the invoice issued for the replacement parts. Credits will be limited to repair parts, labor, and shipping fees directly related to warranty failures. No Credit will be given on non-Pioneer parts.

Any questions regarding Warranty or Return Authorization should be directed to Customer Service at [connerh@pioneerleveler.com](mailto:connerh@pioneerleveler.com) or 1-866-728-6195.



## Warranty claim request form

The Following Information Must Be Supplied To Process Any Claim

Dealer Name: \* \_\_\_\_\_

Contact Person: \* \_\_\_\_\_

Pioneer Invoice Number : \_\_\_\_\_ Date Of Purchase: \_\_\_\_\_

End User Name And address:

Name: \_\_\_\_\_

Address: \_\_\_\_\_

City: \_\_\_\_\_ State: \_\_\_\_\_ Zip: \_\_\_\_\_

Product: \_\_\_\_\_

Model Number: \* \_\_\_\_\_ Serial Number: \* \_\_\_\_\_

Customer Complaint: \* \_\_\_\_\_  
\_\_\_\_\_  
\_\_\_\_\_

Scope of Service Performed: \* \_\_\_\_\_  
\_\_\_\_\_  
\_\_\_\_\_

Estimated Repair: Hours: \* \_\_\_\_\_ \$ \* \_\_\_\_\_

If multiple repairs list hours and \$ for each item.

Pioneer requires an invoice for all claims requiring a payment.

**\*Before And After Pictures Must Be Supplied With All Work Performed**

Purchase a disposable camera and send it to Pioneer along with the receipt.

**\*Required to process all warranty claims.**

## **WARRANTY**

**A ONE YEAR WARRANTY is standard on the Pioneer “EHP” series levelers, to include all structural members. A one year warranty covers the motor/pump assembly, cylinders and miscellaneous parts.**

**Pioneer accepts full responsibility for the cost of materials, labor and freight for any warranty claim during the warranty period, which begins at date of shipment. Pioneer reserves the right to either repair or replace any defective parts. A claim for breach of warranty will be honored if the product has been properly installed, maintained and operated within its rated capacity, and not damaged by abuse.**

**NOTE: Hydraulic valve adjustments are normal maintenance and are not covered under warranty.**

**PIONEER MANUFACTURING, INC. SHALL NOT BE LIABLE FOR LOSS OF USE OF ANY EQUIPMENT OR INCIDENTAL DAMAGES.**

**PIONEER EXPRESSLY DISCLAIMS ANY AND ALL IMPLIED WARRANTIES.**

**All Pioneer products meet or exceed Federal Occupational Safety and Health Act Standards, Commercial Standards 202-56, and American Society of Mechanical Engineers Specifications ANSI MH14.1-84.**

**Warranty Phone: 1.866.728.6195**

0724