

SMART+™ “HDH” Series Hydraulic Leveler Submittal

“HDH” SERIES HYDRAULIC DOCK LEVELER MODEL SPECIFICATIONS

MODEL	LIP*	DECK*	NOMINAL LENGTH	WIDTH	HINGE CF1045	SEAMLESS HINGE TUBE	OPERATING RANGE
HDH6650 / HDH7650	5/8" x 16"	1/4"	6'	72"/83"	1 1/8" diameter	2 3/4" dia. O.D.	+12"-12"
HDH6850 / HDH7850	5/8" x 16"	1/4"	8'	72"/83"	1 1/8" diameter	2 3/4" dia. O.D.	+12"-12"
HDH61050 / HDH71050	5/8" x 16"	1/4"	10'	72"/83"	1 1/8" diameter	2 3/4" dia. O.D.	+16"-16"
HDH6660 / HDH7660	3/4" x 16"	3/8"	6'	72"/83"	1 1/8" diameter	2 3/4" dia. O.D.	+12"-12"
HDH6860 / HDH7860	3/4" x 16"	3/8"	8'	72"/83"	1 1/8" diameter	2 3/4" dia. O.D.	+12"-12"
HDH61060 / HDH71060	3/4" x 16"	3/8"	10'	72"/83"	1 1/8" diameter	2 3/4" dia. O.D.	+16"-16"
HDH6670 / HDH7670	7/8" x 16"	3/8"	6'	72"/83"	1 3/8" diameter	3" dia. O.D.	+12"-12"
HDH6870 / HDH7870	7/8" x 16"	3/8"	8'	72"/83"	1 3/8" diameter	3" dia. O.D.	+12"-12"
HDH61070 / HDH71070	7/8" x 16"	3/8"	10'	72"/83"	1 3/8" diameter	3" dia. O.D.	+16"-16"
HDH6680 / HDH7680	1" x 16"	3/8"	6'	72"/83"	1 3/8" diameter	3" dia. O.D.	+12"-12"
HDH6880 / HDH7880	1" x 16"	3/8"	8'	72"/83"	1 3/8" diameter	3" dia. O.D.	+12"-12"
HDH61080 / HDH71080	1" x 16"	3/8"	10'	72"/83"	1 3/8" diameter	3" dia. O.D.	+16"-16"

INSERT SPECIFIC JOB REQUIREMENTS FROM CHART

--	--	--	--	--	--	--	--

STANDARD CAPACITY

A.N.S.I. CAPACITY

--	--

*Lip and deck, 55,000 lb. minimum yield steel; 5 year structural warranty.
 **Models with deck width of 78" (6 1/2') are available upon request.

STANDARD FEATURES

- (2) Laminated Bumpers
- Lip 16"
- Grease Fittings
- Maintenance Strut
- Lip Keepers/Night Locks
- Fully Hydraulic Actuation
- Automatic Recycle
- Below Dock Control
- Automatic Cant Feature
- Deck Support, Structural C Channel
- In-line Safety Stop (prevents free-fall)
- Yellow & Black Diagonal Safety Stripe on Toe Guards
- Motor--1 hp. 1 ph. 60Hz
 - 115 Volt
- Full Range Toe Guards (Powder Coated Yellow)

OPTIONAL FEATURES

- Lip 18"
- Lip 20"
- Weather Seals
- Foam Insulation
- Abrasive Deck
- Emergency Stop
- Three Wheel Fork Lift
- Deep Pit Kit
- 1 Phase Motor
- 208 Volt
- 230 Volt
- 3 Phase Motor
- 208 Volt
- 230 Volt
- 460 Volt
- Hot Dip Galvanize
- SMART+™ Versa Panel
- Laminated Bumper
- Size
- Four Sided Pans
- Three Sided (E-Z) Pans
- Independent Lip Control



PO Box 338 • Spring Hill, Tennessee 37174
 931.486.2296 • 800.251.3382 • Fax: 931.486.0316
 www.pioneerleveler.com

JOB

Pioneer reserves the right to make product improvement at any time without prior notice.

SMART+™ “HDH” Series Hydraulic Leveler Submittal

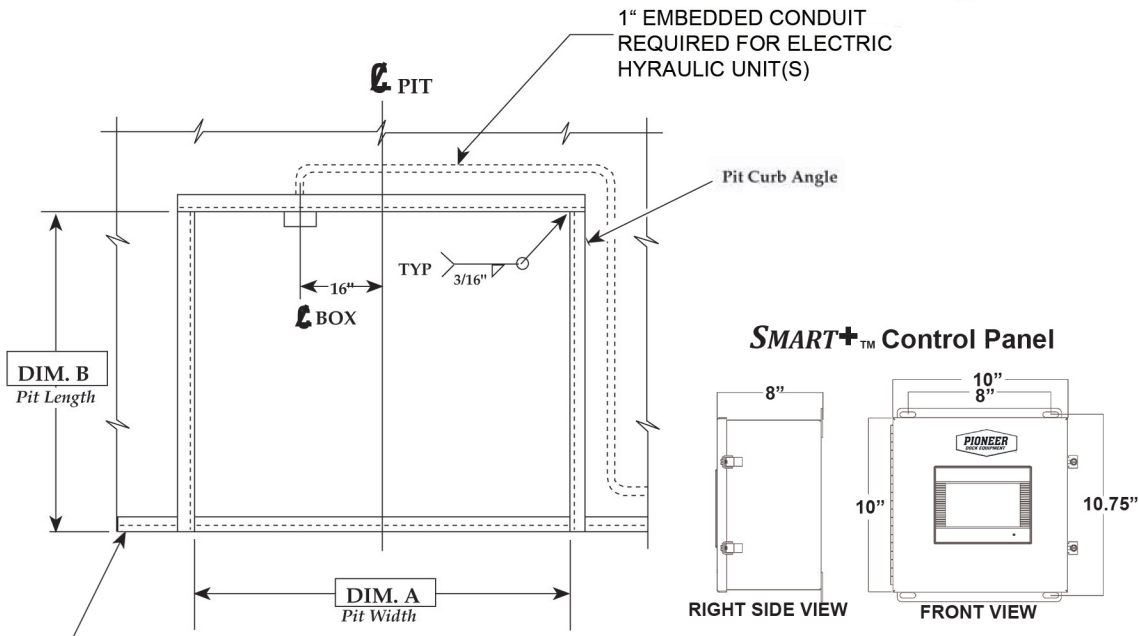

VARIABLE DIMENSIONS				
MODEL	“A”	“B”	“C”	“D”
6’W x 6’L	74”	63”	19 1/2”	20”
6’W x 8’L	74”	87”	19 1/2”	20”
6’-6”W x 6’L	80”	63”	19 1/2”	20”
6’-6”W x 8’L	80”	87”	19 1/2”	20”
7’W x 6’L	85”	63”	19 1/2”	20”
7’W x 8’L	85”	87”	19 1/2”	20”
6’W x 10’L	74”	111”	23 1/2”	24”
6’-6”W x 10’L	80”	111”	23 1/2”	24”
7’W x 10’L	85”	111”	23 1/2”	24”

INSERT SPECIFIC JOB DIMENSIONS FROM CHART

--	--	--	--	--

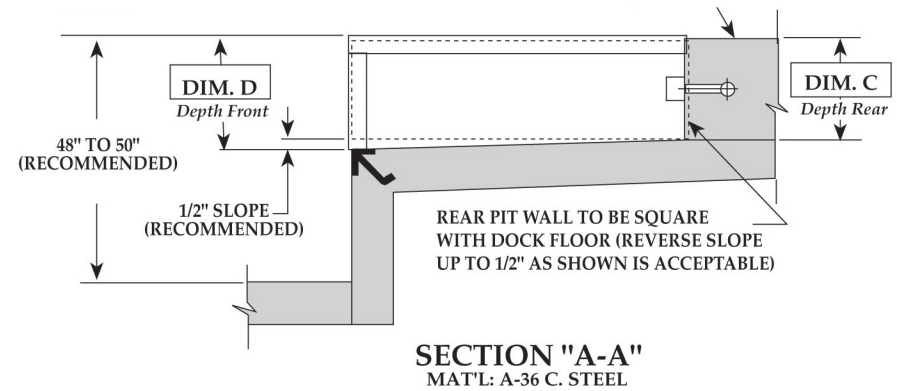
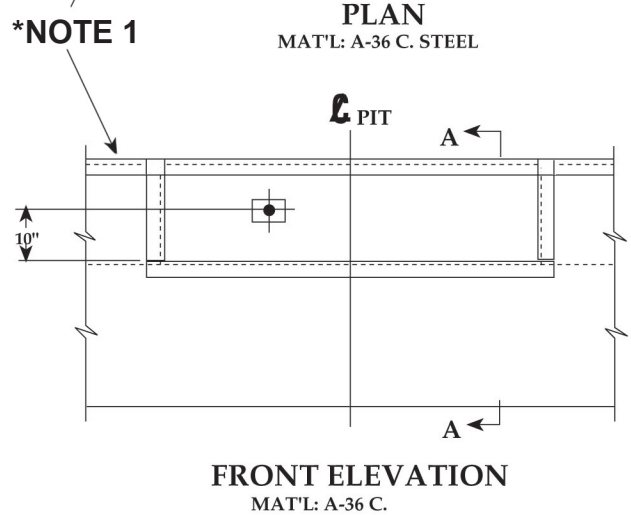

***NOTE 1 :** Angle 3”x3”x1/4”x20”
Minimum Length or Run
Continuous Pit to Pit.
(Supplied By Others)

DRAWN :	SCALE: AS NOTED	DATE: 1/30/95	DRAWING NUMBER:
---------	-----------------	---------------	-----------------

TOLERANCES		
Inch Dimension = 1/16”	Decimal Dimension = .005	Angles = 1



PO Box 338 • Spring Hill, Tennessee 37174
931.486.2296 • 800.251.3382 • Fax: 931.486.0316
www.pioneerleveler.com

JOB

Pioneer reserves the right to make product improvement at any time without prior notice.